

STEPPER MOTOR DRIVER

- FULL STEP - HALF STEP - QUARTER STEP OPERATING MODE
- BIPOLEAR OUTPUT CURRENT UP TO 1 A
- FROM 10 V UP TO 46 V MOTOR SUPPLY VOLTAGE
- LOW SATURATION VOLTAGE WITH INTEGRATED BOOTSTRAP
- BUILT IN FAST PROTECTION DIODES
- EXTERNALLY SELECTABLE CURRENT LEVEL
- OUTPUT CURRENT LEVEL DIGITALLY OR ANALOGUE CONTROLLED
- THERMAL PROTECTION WITH SOFT INTERVENTION

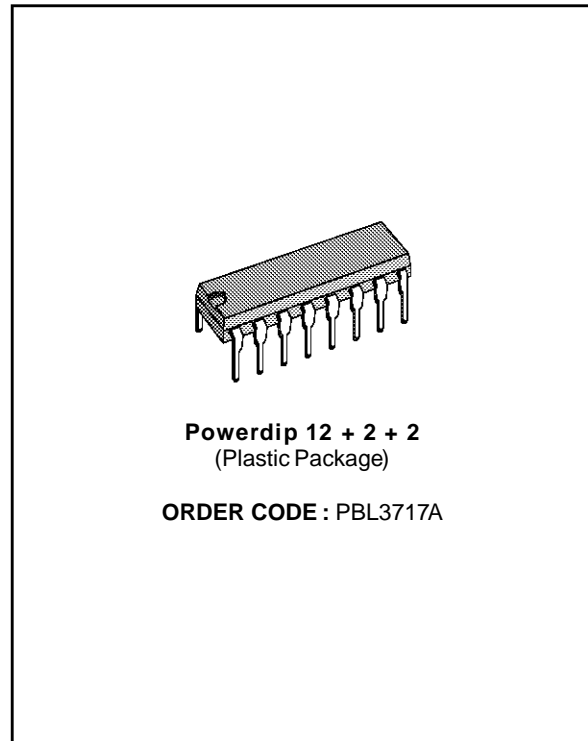

DESCRIPTION

The PBL3717A is a monolithic IC which controls and drives one phase of a bipolar stepper motor with chopper control of the phase current. Current levels may be selected in three steps by means of two logic inputs which select one of three current comparators. When both of these inputs are high the device is disabled. A separate logic input controls the direction of current flow.

A monostable, programmed by an external RC network, sets the current decay time.

The power section is a full H-bridge driver with four internal clamp diodes for current recirculation. An external connection to the lower emitters is available for the insertion of a sensing resistor. Two PBL3717As and few external components form a complete stepper motor drive subsystem.

The recommended operating ambient temperature ranges is from 0 to 70 °C.

The PBL3717A is supplied in a 12 + 2 + 2 lead Powerdip package.

PIN CONNECTION (top view)

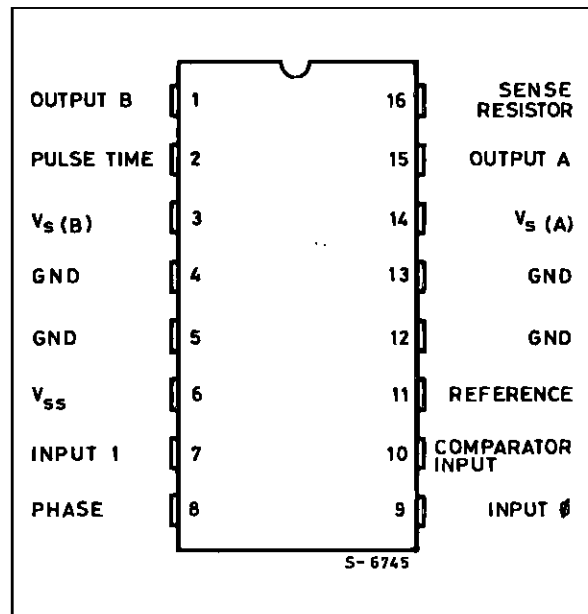

PIN FUNCTIONS

N°	Name	Function
1	OUTPUT B	Output Connection (with pin 15). The output stage is a "H" bridge formed by four transistors and four diodes suitable for switching applications.
2	PULSE TIME	A parallel RC network connected to this pin sets the OFF time of the lower power transistors. The pulse generator is a monostable triggered by the rising edge of the output of the comparators ($t_{off} = 0.69 R_T C_T$).
3	SUPPLY VOLTAGE B	Supply Voltage Input for Half Output Stage See also pin 14.
4	GROUND	Ground Connection. With pins 5, 12 and 13 also conducts heat from die to printed circuit copper.
5	GROUND	See pin 4.
6	LOGIC SUPPLY	Supply Voltage Input for Logic Circuitry
7	INPUT 1	This pin and pin 9 (INPUT 0) are logic inputs which select the outputs of the three comparators to set the current level. Current also depends on the sensing resistor and reference voltage. See truth table.
8	PHASE	This TTL-compatible logic input sets the direction of current flow through the load. A high level causes current to flow from OUTPUT A (source) to OUTPUT B (sink). A schmitt trigger on this input provides good noise immunity and a delay circuit prevents output stage short circuits during switching.
9	INPUT 0	See INPUT 1 (pin 7) .
10	COMPARATOR INPUT	Input connected to the three comparators. The voltage across the sense resistor is feedback to this input through the low pass filter $R_C C_C$. The lower power transistor are disabled when the sense voltage exceeds the reference voltage of the selected comparator. When this occurs the current decays for a time set by $R_T C_T$, $t_{off} = 0.69 R_T C_T$.
11	REFERENCE	A voltage applied to this pin sets the reference voltage of the three comparators, this determining the output current (also thus depending on R_s and the two inputs INPUT 0 and INPUT 1).
12	GROUND	See pin 4.
13	GROUND	See pin 4.
14	SUPPLY VOLTAGE A	Supply Voltage Input for Half Output Stage. See also pin 13.
15	OUTPUT A	See pin 1.
16	SENSE RESISTOR	Connection to Lower Emitters of Output Stage for Insertion of Current Sense Resistor

TRUTH TABLE

Input 0 (pin 9)	Input 1 (pin 7)	
H	H	No Current
L	H	Low Current
H	L	Medium Current
L	L	High Current

BLOCK DIAGRAM

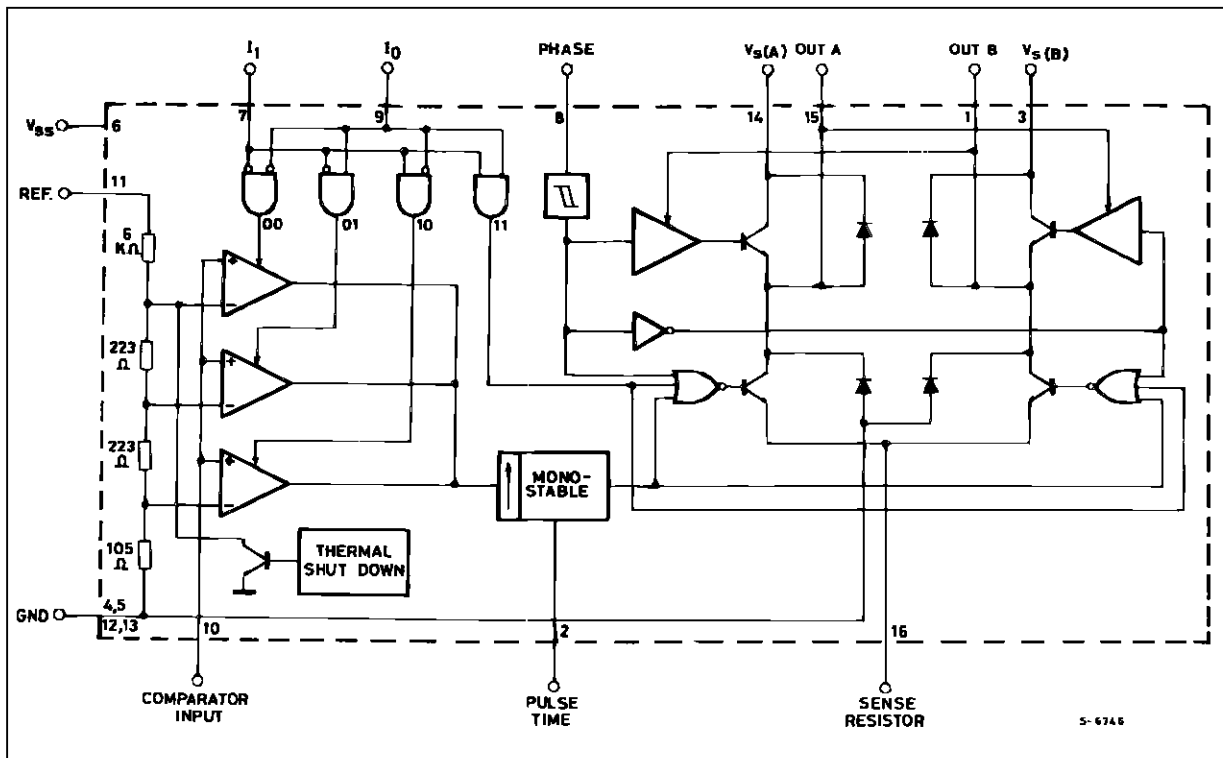

ABSOLUTE MAXIMUM RATINGS

Symbol	Parameter	Value	Unit
V_s	Power Supply Voltage	50	V
V_{ss}	Logic Supply Voltage	7	V
V_i	Logic Input Voltage	6	V
V_c	Comparator Input	V_{ss}	
V_r	Reference Input Voltage	15	V
I_o	Output Current (DC operation)	1.2	A
T_{stg}	Storage Temperature	- 55 to + 150	°C
T_j	Operating Junction Temperature	150	°C

THERMAL DATA

Symbol	Parameter	Value	Unit
$R_{th j-case}$	Thermal Resistance Junction-pins	11	°C/W
$R_{th j-amb}$	Thermal Resistance Junction-ambient*	40	°C/W

* Soldered on a 35μ thick 20 cm² P.C. board copper area.

ELECTRICAL CHARACTERISTICS

(refer to the test circuit $V_s = 36V$, $V_{SS} = 5V$, $T_{amb} = 25^\circ C$ unless otherwise specified)

Symbol	Parameter	Test Conditions	Min.	Typ.	Max.	Unit
V_s	Supply Voltage (pin 3, 14)		10		46	V
V_{SS}	Logic Supply Voltage (pin 6)		4.75		5.25	V
I_{SS}	Logic Supply Current (pin 6)			7	15	mA
I_R	Reference Input Current (pin 11)	$V_R = 5V$		0.75	1	mA

LOGIC INPUTS

V_{iL}	Input Low Voltage (pins 7, 8, 9)				0.8	V
V_{iH}	Input High Voltage (pin 7, 8, 9)		2		V_{SS}	V
I_{iL}	Low Voltage Input Current (pins 7, 8, 9)	$V_i = 0.4V$ pin 8 pins 7, 9			- 100 - 400	μA μA
I_{iH}	High Voltage Input Current (pins 7, 8, 9)	$V_i = 2.4V$			10	μA

COMPARATORS

V_{CL}	Comparator Low Threshold Voltage (pin 10)	$V_R = 5V$ $I_o = L$ $I_1 = H$	66	78	90	mV
V_{CM}	Comparator Medium Threshold Voltage (pin 10)	$V_R = 5V$ $I_o = L$ $I_1 = H$	236	251	266	mV
V_{CH}	Comparator High Threshold Voltage (pin 10)	$V_R = 5V$ $I_o = L$ $I_1 = H$	396	416	436	mV
I_C	Comparator Input Current (pin 10)				± 20	μA
t_{off}	Cutoff Time	$R_T = 56k\Omega$ $C_T = 820pF$	25		35	μs
t_d	Turn Off Delay	(see fig. 2)			2	μs
I_{off}	Output Leakage Current (pins 1, 15)	$I_o = H$ $I_1 = H$			100	μA

SOURCE DIODE-TRANSISTOR PAIR

V_{sat}	Saturation Voltage (pins 1, 15)	$I_M = - 0.5A$ (see fig. 2) Conduction Period Recirculation Period		1.7 1.1	2.1 1.35	V
V_{sat}	Saturation Voltage (pins 1, 15)	$I_M = - 1A$ (see fig. 2) Conduction Period Recirculation Period		2.1 1.7	2.8 2.5	V
I_{LK}	Leakage Current	$V_s = 46V$			300	μA
V_F	Diode Forward Voltage	$I_M = - 0.5A$ $I_M = - 1A$		1 1.3	1.25 1.7	V V
I_{SLK}	Substrate Leakage Current when Clamped	$I_M = - 0.5A$ $I_M = - 1A$			2 5	mA mA

SINK DIODE-TRANSISTOR PAIR

V_{sat}	Saturation Voltage (pins 1, 15)	$I_M = 0.5A$ $I_M = 1A$		1.1 1.6	1.35 2.3	V V
I_{LK}	Leakage Current	$V_s = 46V$			300	μA
V_F	Diode Forward Voltage	$I_M = 0.5A$ $I_M = 1A$		1.1 1.4	1.5 2	V V

Figure 1 : Test and Application Circuit

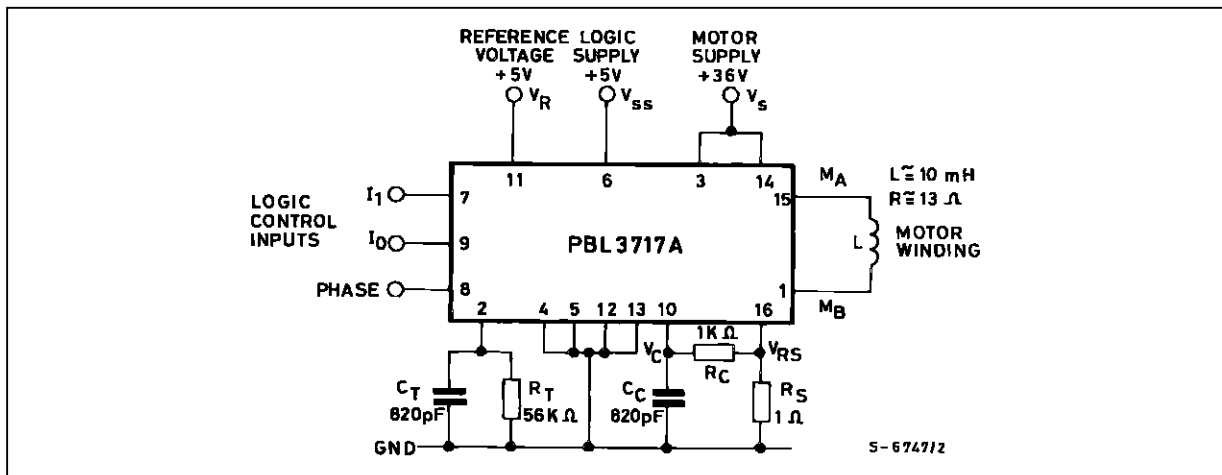
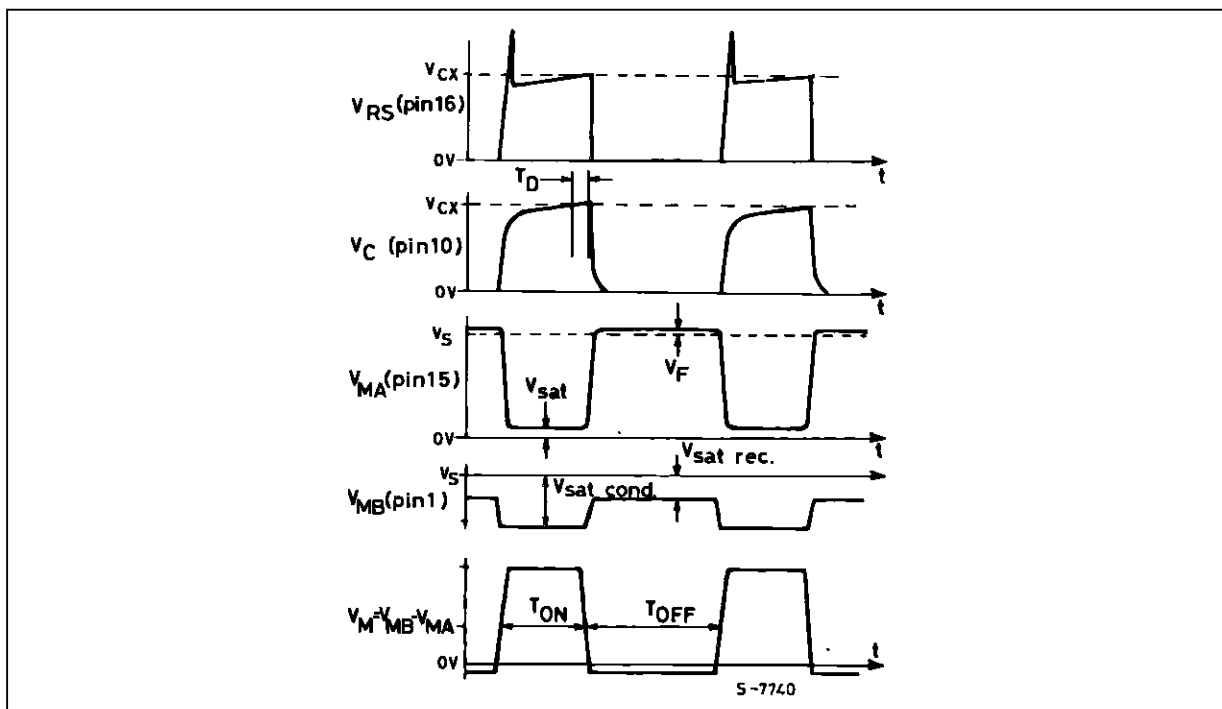

Figure 2 : Waveforms with MA Regulating (phase = 0)



PBL3717A

Figure 3 : Two Phase Bipolar Stepper Motor Driver

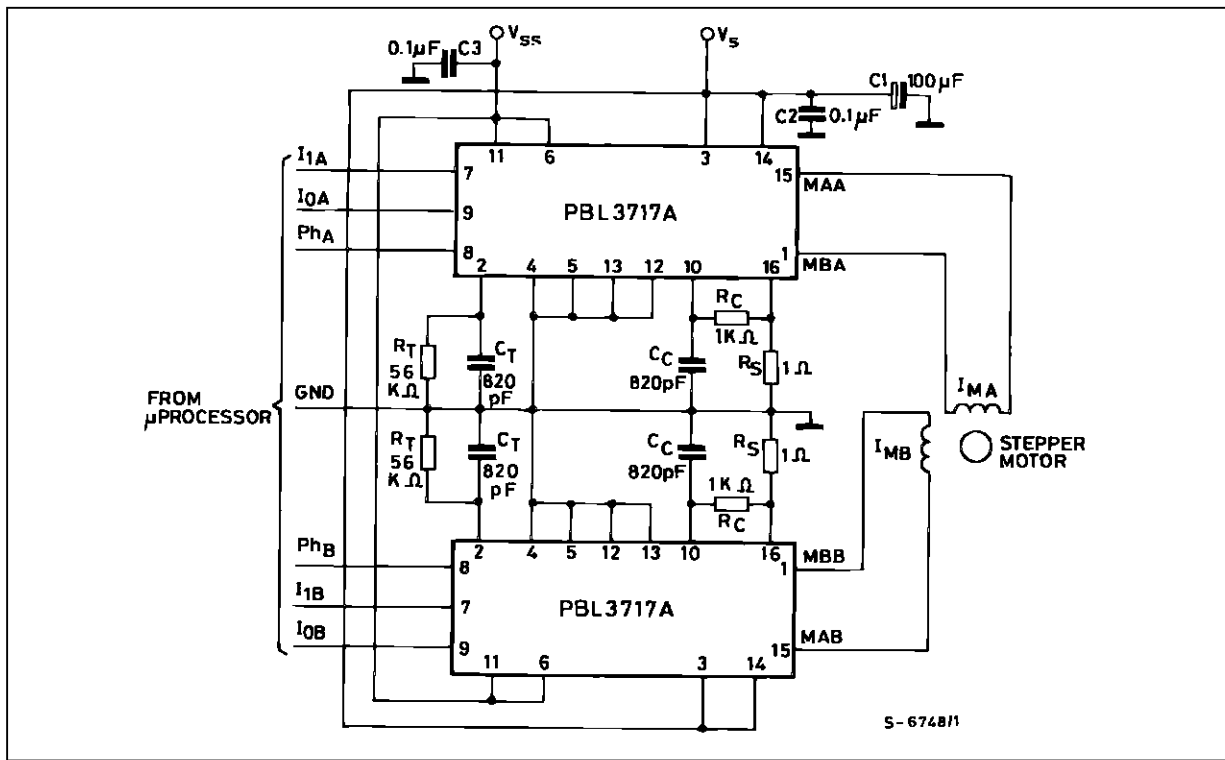

Figure 4 : P.C. Board and Component Layout of the Circuit of fig. 3 (1 : 1 scale)

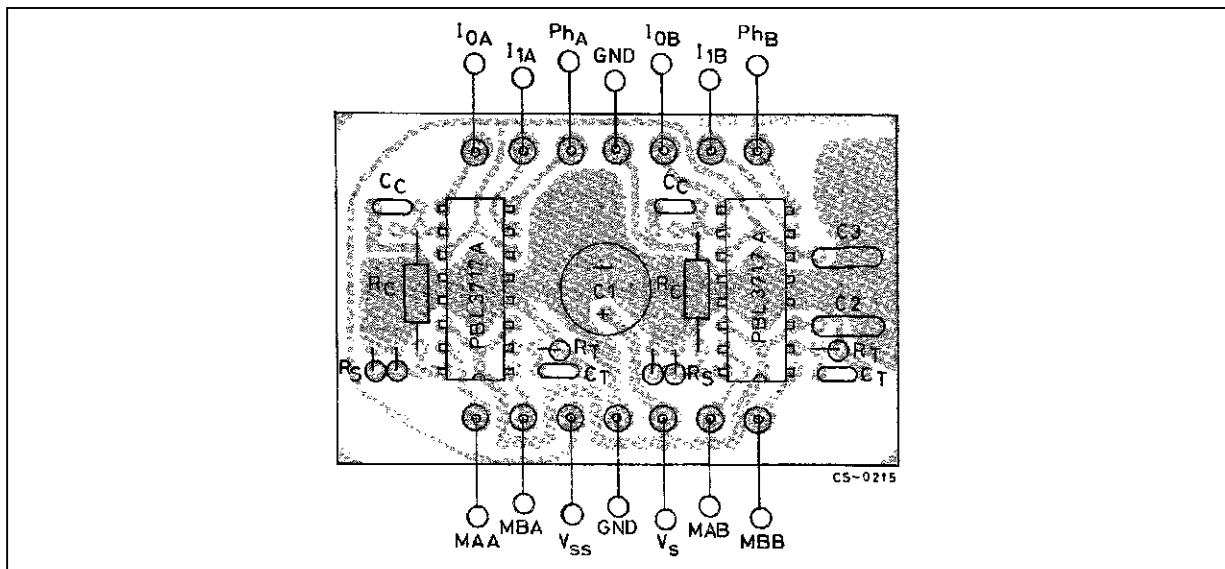
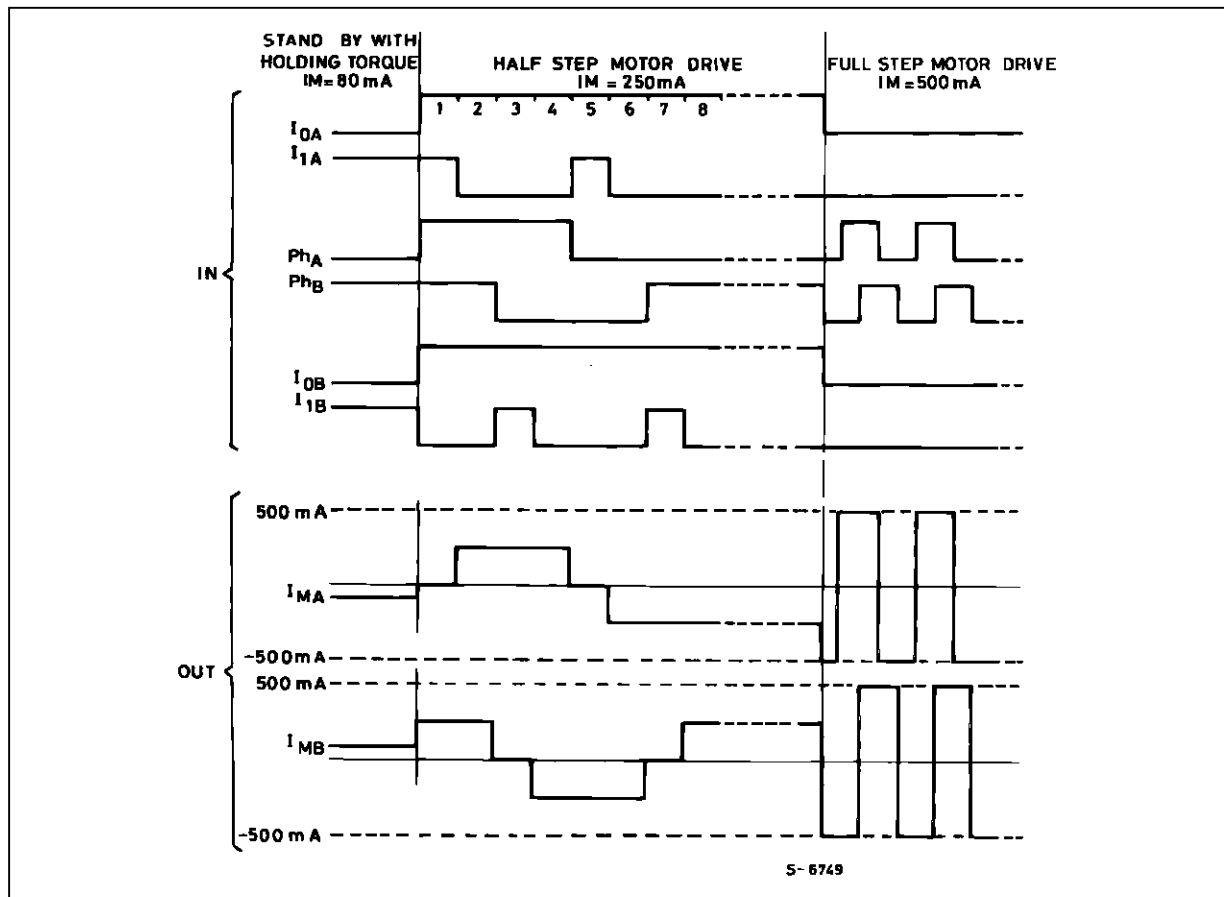

Figure 5 : Input and Output Sequences for Half Step and Full Step Operation



APPLICATION INFORMATIONS

Figure 3 shows a typical application in which two PBL3717A control a two phase bipolar stepper motor.

Programming

The logic inputs I_0 and I_1 set at three different levels the amplitude of the current flowing in the motor winding according to the truth table of page 2. A high level on the "PHASE" logic input sets the direction of that current from output A to output B ; a low level from output B to output A.

It is recommended that unused inputs are tied to pin 6 (V_{SS}) or pin 4 (GND) as appropriate to avoid noise problem.

The current levels can be varied continuously by changing the ref. voltage on pin 11.

Control of the Motor

The stepper motor can rotate in either directions according to the sequence of the input signals. It is possible to obtain a full step, a half step and a quarter step operation.

Full Step Operation

Both the windings of the stepper motor are energized all the time with the same current $I_{MA} = I_{MB}$. I_0 and I_1 remain fixed at whatever torque value is required.

Calling A the condition with winding A energized in one direction and \bar{A} in the other direction, the sequence for full step rotation is :

$$AB \rightarrow \bar{A}B \rightarrow \bar{A}\bar{B} \rightarrow A\bar{B} \text{ etc.}$$

For the rotation in the other direction the sequence must be reserved.

In the full step operation the torque is constant each step.

Half Step Operation

Power is applied alternately to one winding then both according to the sequence :

$$AB \rightarrow B \rightarrow \bar{A}B \rightarrow \bar{A} \rightarrow \bar{A}\bar{B} \rightarrow \bar{B} \rightarrow A\bar{B} \rightarrow A \text{ etc.}$$

Like full step this can be done at any current level ; the torque is not constant but it is lower when only one winding is energized.

A coil is turned off by setting I_0 and I_1 both high.

PBL3717A

Quarter Step Operation

It is preferable to realize the quarter step operation at full power otherwise the steps will be of very irregular size.

The extra quarter steps are added to the half steps sequence by putting one coil on half current according to the sequence.

$$AB \rightarrow \frac{A}{2} B \rightarrow B \rightarrow \frac{\bar{A}}{2} B \rightarrow \bar{A} B \rightarrow A \frac{B}{2} \rightarrow \bar{A} \text{ etc.}$$

Motor Selection

As the PBL3717A provides constant current drive, with a switching operation, care must be taken to select stepper motors with low hysteresis losses to prevent motor over heat.

L -C Filter

To reduce EMI and chopping losses in the motor a low pass L -C filter can be inserted across the outputs of the PBL3717A as shown on the following picture.

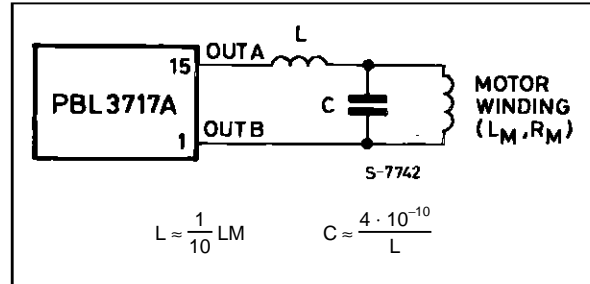

Figure 6 : Source Saturation Voltage versus Output Current (recircuit period)

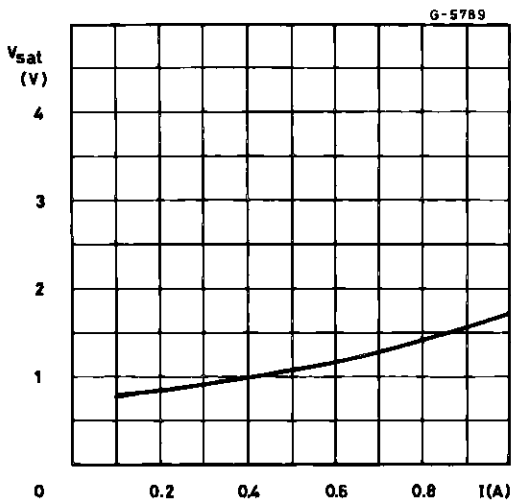

Figure 8 : Sink Saturation Voltage versus Output Current

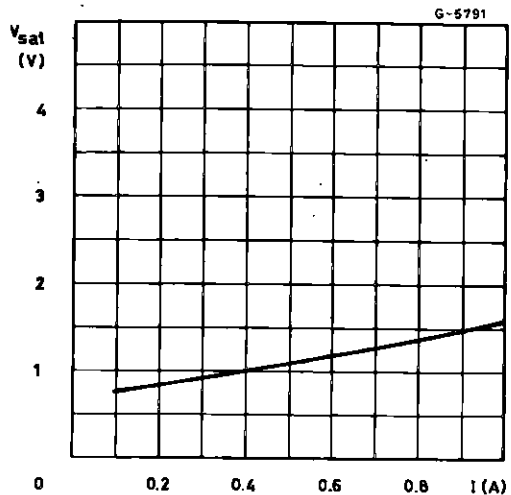

Figure 7 : Source Saturation Voltage versus Output Current (conduction period)

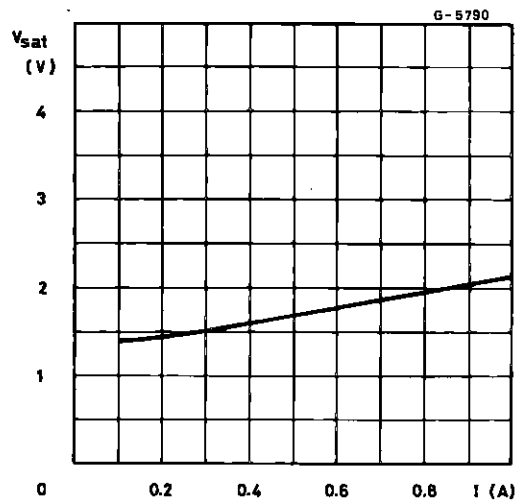
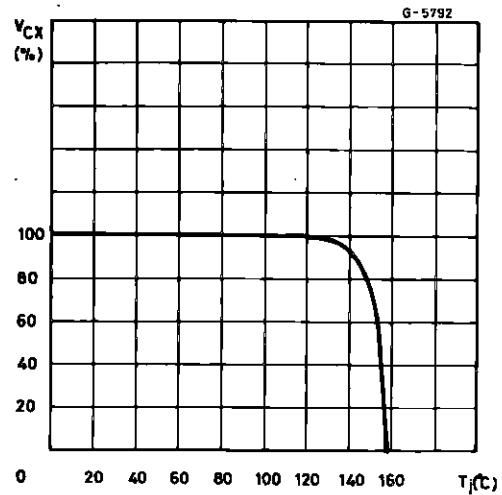

Figure 9 : Comparator Threshold versus Junction Temperature



MOUNTING INSTRUCTIONS

The $R_{th\ j-amb}$ of the PBL 3717A can be reduced by soldering the GND pins to a suitable copper area of the printed circuit board or to an external heatsink.

Figure 10 : Example of P.C. Board Copper Area which is used as Heatsink

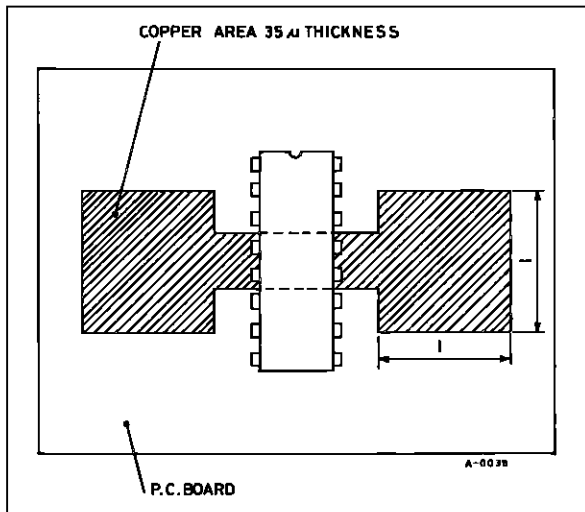

The diagram of fig. 11 shows the maximum dissippable power P_{tot} and the $R_{th\ j-amb}$ as a function of the side "a" of two equal square copper areas having a thickness of 35μ (see fig. 10).

Figure 11 : Max. Dissippable Power and Junction-Ambient Thermal Resistance versus size "a"

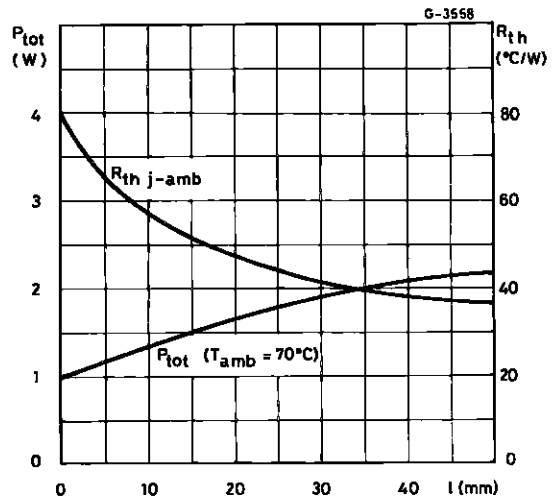

PBL3717A

POWERDIP16 PACKAGE MECHANICAL DATA

DIM.	mm			inch		
	MIN.	TYP.	MAX.	MIN.	TYP.	MAX.
a1	0.51			0.020		
B	0.85		1.40	0.033		0.055
b		0.50			0.020	
b1	0.38		0.50	0.015		0.020
D			20.0			0.787
E		8.80			0.346	
e		2.54			0.100	
e3		17.78			0.700	
F			7.10			0.280
I			5.10			0.201
L		3.30			0.130	
Z			1.27			0.050

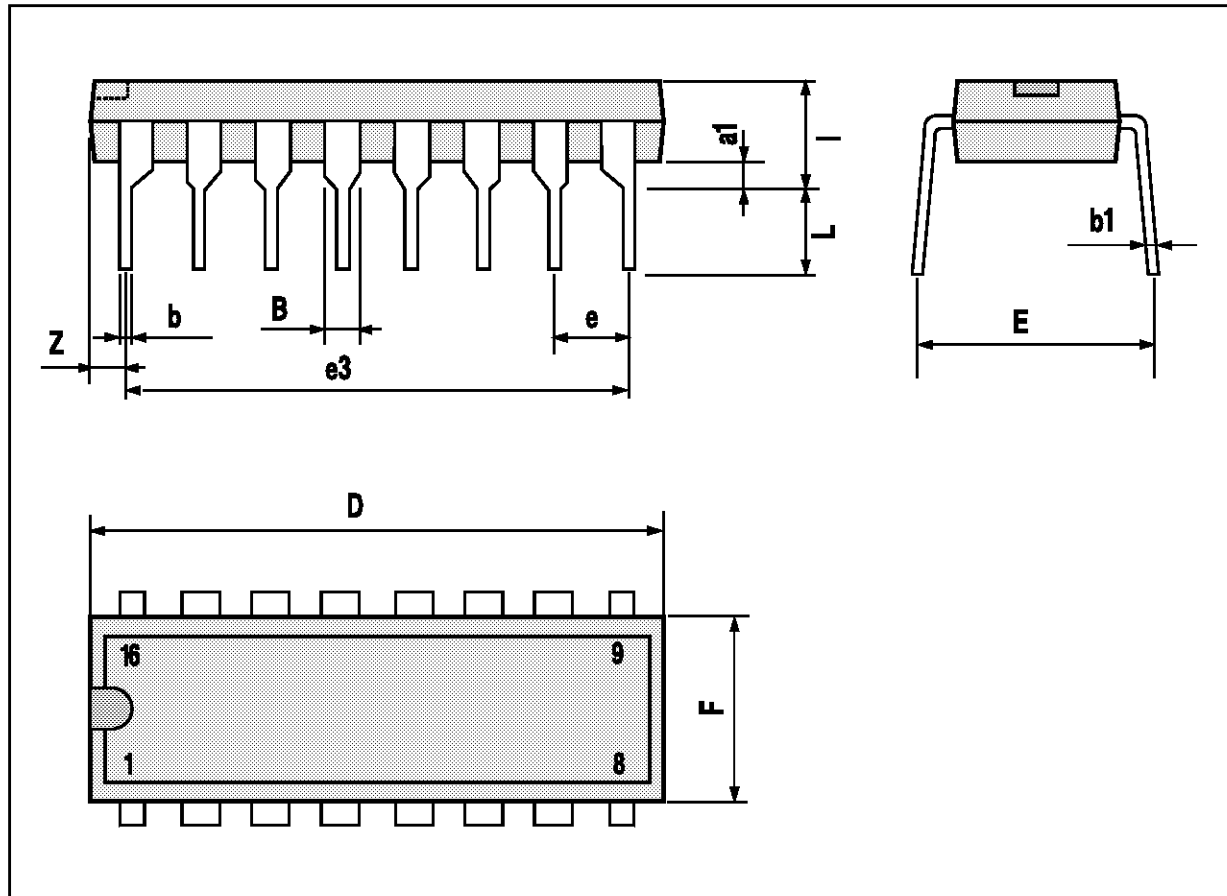

Information furnished is believed to be accurate and reliable. However, SGS-THOMSON Microelectronics assumes no responsibility for the consequences of use of such information nor for any infringement of patents or other rights of third parties which may result from its use. No license is granted by implication or otherwise under any patent or patent rights of SGS-THOMSON Microelectronics. Specifications mentioned in this publication are subject to change without notice. This publication supersedes and replaces all information previously supplied. SGS-THOMSON Microelectronics products are not authorized for use as critical components in life support devices or systems without express written approval of SGS-THOMSON Microelectronics.

© 1994 SGS-THOMSON Microelectronics - All Rights Reserved

SGS-THOMSON Microelectronics GROUP OF COMPANIES

Australia - Brazil - France - Germany - Hong Kong - Italy - Japan - Korea - Malaysia - Malta - Morocco - The Netherlands - Singapore - Spain - Sweden - Switzerland - Taiwan - Thailand - United Kingdom - U.S.A.